



FairPoint Wholesale User Forum Agenda & Opening Remarks

John Berard

October 30, 2008

Agenda - Opening Remarks

Webex and Conference Call Etiquette



- Mute Phones when not speaking *6 (*6 again to un-mute)
- Never put your phone on hold to take another call (avoids music on hold) 🎵 🎵
- State your name and company when speaking
- Ask Questions at the end of the slide not in the middle.
 - Two options (raise hand on Webex or un-mute and ask your question)



Agenda - Morning Session

10:00 AM to 10:10 AM	Introductions / Agenda - John Berard
10:10 AM to 11:00 AM	Tour of the FairPoint Wholesale Website - John Berard and Henry Lopez
11:00 AM to 12:00 PM	Connectivity to FairPoint Systems / Wholesale Portal - Laura Talbert, Michael Tartaglione, Pat Block, Deb Wall, Claudia D'Amato, John Berard
12:00 PM to 12:30 PM	Lunch Break
01:00 PM to 02:00 PM	Question and Answer Review - Rich Murtha and John Berard
02:00 PM to 03:00 PM	Embargo Process, Hot Cut Process, and Interval Guide



FairPoint Wholesale User Forum Tour of the FairPoint Wholesale Website

John Berard, Director Wholesale Customer Relations

Henry Lopez, Manager Wholesale Customer Relations

October 30, 2008



FairPoint Wholesale User Forum Connectivity Issues / Wholesale Portal

Laura Talbert , Michael Tartaglione, Deb Wall, Pat Block, Claudia D'Amato, John Berard

October 30, 2008

Wholesale Customer Checklist - John Berard

APPLICATION	FAIRPOINT CONNECTION OPTIONS	FAIRPOINT CONTACT NAME PHONE/EMAIL	3RD PARTY CONTACT NAME PHONE/EMAIL
LSR ORDERING	<p>Available via GUI or eBonding.</p> <p>eBonding: Please refer to the connectivity guide on the FairPoint Wholesale Website for connection options.</p>	<p>For GUI contact Eloise Goodson 207-648-3210 egoodson@fairpoint.com</p> <p>For eBonding contact Linda Birchem 207-648-3214 lbirchem@fairpoint.com</p> <p>To reach the FairPoint OSS Change Management team you can e-mail: fairpointcmp@fairpoint.com</p>	<p>If you are an eBonded customer should already be connected to the Wisor VFO at this time. If you have questions please contact Linda on 207 648 3214 or send an email to fairpointcmp@fairpoint.com</p> <p>If you are a GUI user please return your VFO connectivity Form to fairpointcmp@fairpoint.com By November 3, 2008 see FairPoint Accessible Letter: SYS 0029-10272008</p>

Wholesale Customer Checklist - John Berard

APPLICATION	FAIRPOINT CONNECTION OPTIONS	FAIRPOINT CONTACT NAME PHONE/EMAIL	3RD PARTY CONTACT NAME PHONE/EMAIL
ASR ORDERING	<p>Available via GUI or eBonding.</p> <p>eBonding: Please refer to the connectivity guide on the FairPoint Wholesale Website for connection options.</p>	<p>For GUI contact Eloise Goodson 207-648-3210 egoodson@fairpoint.com</p> <p>For eBonding contact Linda Birchem 207-648-3214 lbirchem@fairpoint.com</p> <p>To reach the FairPoint OSS Change Management team you can e-mail: fairpointcmp@fairpoint.com</p>	<p>If you are an eBonded customer should already be connected to the Wisor VFO at this time. If you have questions please contact Linda on 207 648 3214 or send an email to fairpointcmp@fairpoint.com</p> <p>If you are a GUI user please return your VFO connectivity Form to fairpointcmp@fairpoint.com By November 3, 2008 see FairPoint Accessible Letter: SYS 0029-10272008</p>

Wholesale Customer Checklist - John Berard

APPLICATION	FAIRPOINT CONNECTION OPTIONS	FAIRPOINT CONTACT NAME PHONE/EMAIL	3RD PARTY CONTACT NAME PHONE/EMAIL
<p>TROUBLE ADMINISTRATION</p>	<p>Available via GUI or eBonding.</p> <p>eBonding: Please Refer to the connectivity guide on the FairPoint Wholesale Website for connection options.</p>	<p>For GUI contact Eloise Goodson 207-648-3210 egoodson@fairpoint.com</p> <p>For eBonding contact Linda Birchem 207-648-3214 lbirchem@fairpoint.com</p> <p>To reach the FairPoint OSS Change Management team you can email: fairpointcmp@fairpoint.com</p>	<p>If you are an eBonded customer should already be connected to the Wisor VFO at this time. If you have questions please contact Linda on 207 648 3214 or send an email to fairpointcmp@fairpoint.com</p> <p>If you are a GUI user please return your VFO connectivity Form to fairpointcmp@fairpoint.com By November 3, 2008 see FairPoint Accessible Letter: SYS 0029-10272008</p>

Wholesale Interconnection - Conceptual View - John Berard

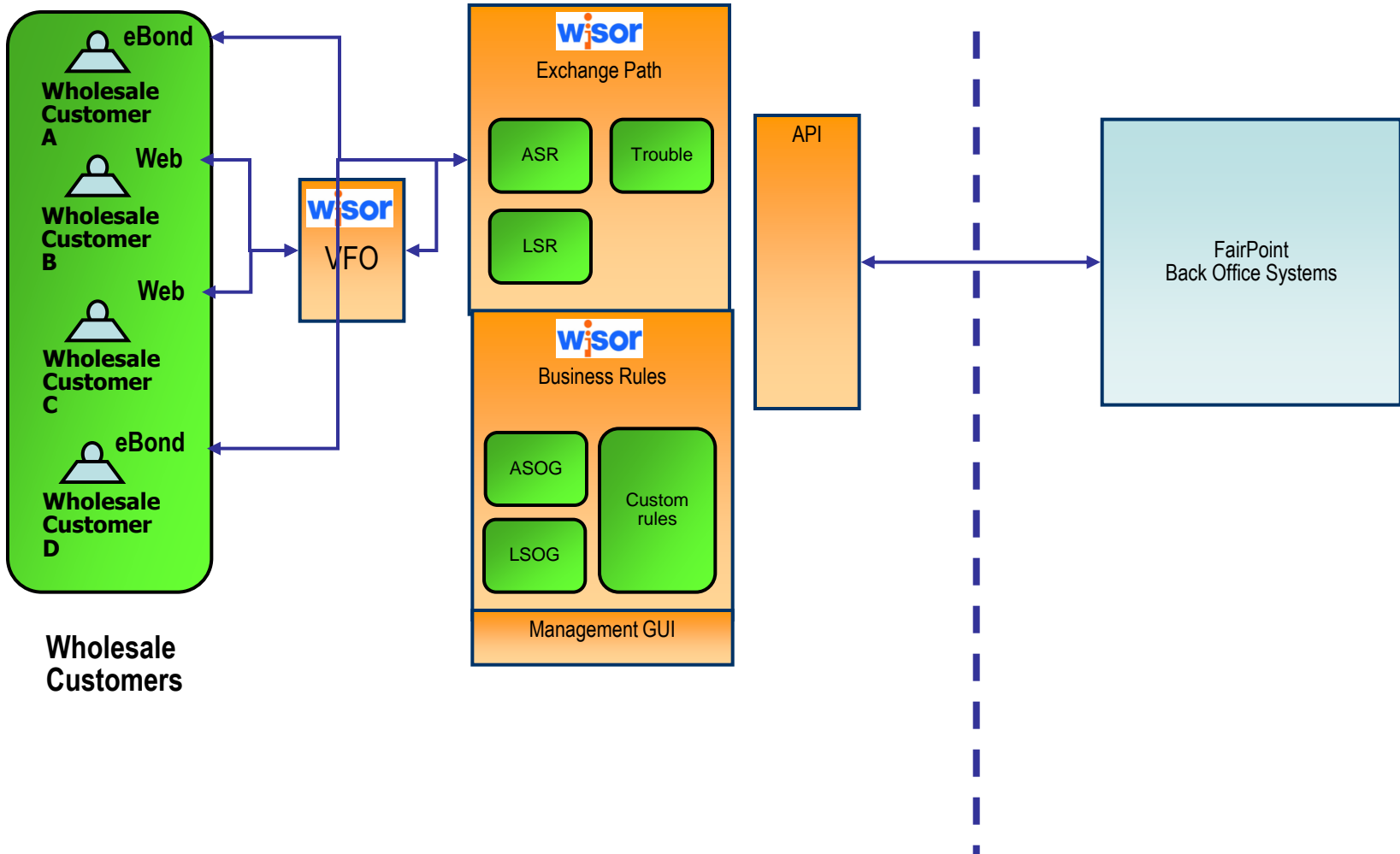

Wisor VFO: Interconnection Gateway - John Berard

■ LSR

- Message format is EDI (based on Verizon EDI mappings)
- Business rules are LSOG 9.12.1
- Transport is Interactive Agent (versions 2 and 3 are both supported)

■ ASR

- ASOG 37 current version
- Message format is Mechspec
- XML over HTTP is supported
- Transport is Connect: Direct

■ Trouble Administration

- Industry-standard TA-"Agent"
- Message format is tML
- Transport is HTTP

eBonding Connectivity Options

1. HTTPS (encrypted using SSL) via the Internet
2. VPN tunneling
3. A private dedicated circuit

Wholesale Customer Checklist - Laura Talbert

APPLICATION	FAIRPOINT CONNECTION OPTIONS	FAIRPOINT CONTACT NAME PHONE/EMAIL	3RD PARTY CONTACT NAME PHONE/EMAIL
DUF FILES	available SFTP via VPN tunnel, NDM via VPN tunnel or NDM via T1	billingconnectivity@fairpoint.com or Cheryl Engelhardt or Laura Talbert (207) 648-3442	KDM (Kenan Data Mediation) FairPoint system in Manchester Data Center

Wholesale Technical Guide provided on 10/29.

Contact billingconnectivity@fairpoint.com for a copy.

Connectivity - Daily Usage File - Laura Talbert

- Process
 - Complete Wholesale Billing Questionnaire
 - Email to billingconnectivity@fairpoint.com
 - Cheryl Engelhardt 207-648-3442
- Next Steps – VPN Tunnel
 - VPN Account Request form emailed to contact provided in questionnaire which includes FairPoint VPN information.
 - Completed form, including all signatures returned for internal FairPoint approval.
 - Once form is approved, conference call setup between customer and FairPoint IT Network.

Connectivity - Daily Usage File - Laura Talbert

- Following call, Pre-shared Keys are exchanged and connectivity established.
- Next Steps – T1
 - FairPoint provided customer with information needed to order T1.
 - Direct Circuit Connectivity Form emailed to customer for completion and signature.
 - Once customer notifies FairPoint that the T1 has been installed, a call is held with FairPoint IT Network

Connectivity - Daily Usage File - Laura Talbert

- SFTP
 - Customer generates Secure Keys and provides FairPoint with public key which is loaded into our server.
 - Username and Password are exchanged
- Connect.Direct (NDM)
 - A call is held between the customer and FairPoint establishing connection.
 - At this time, Connect.Direct connectivity is only available for test instance. Production connectivity will be established in the future.

Connectivity - Daily Usage File - Laura Talbert

- Testing:
 - Sample files are requested from customer on questionnaire.
 - Test files provided to customer using extract data from Verizon, usually through email.
 - Additional test files are provided using current usage data polled by FairPoint systems.
- Future Step:
 - On November 24, FairPoint will start scheduling calls for moving all partners using NDM onto Production.

Wholesale Customer Checklist

Michael Tartaglione and Pat Block

APPLICATION	FAIRPOINT CONNECTION OPTIONS	FAIRPOINT CONTACT NAME PHONE/EMAIL	3RD PARTY CONTACT NAME PHONE/EMAIL
Resale Bill	Provided via NDM Direct Connect, Paper,	Pat Block, Wholesale Billing and CABS pblock@fairpoint.com (207) 648-3307	Kenan
Wholesale (CABS) Bill	Provided by CDG available on CD, Paper and FTP. Direct connections can be established via VPN Tunnel or Frame Relay Service.	Pat Block, Director, Wholesale Billing and CABS pblock@fairpoint.com (207) 648-3307	CDG
MEET POINT BILLING RECORDS	Available via NDM Direct Connect	Laura Talbert, Manager, Wholesale Production Control BillingConnectivity@fairpoint.com (207) 648-3213	CDG
CARE RECORDS (convert from XEA)	NDM via VPN or T1, FTP, GUI or email	Pat Block, Director, Wholesale Billing and CABS pblock@fairpoint.com (207) 648-3307	NeuStar CARE Clearinghouse 1-866-638-9600 (Prompt #1) Careops@neustar.biz

Connectivity - Billing / CDG - Michael Tartaglione

Verizon's CABS billing conversion to CDG's carrier access system

- Post cutover CDG will:
 - Replicate existing Verizon Bill cycles
 - Issue Invoices in Bill Data Tape (BDT)/Customer Service Record (CSR) format, although CSR's are optional.
 - Maintain C/BOS Version 48 standard - the most current release for BDT, CSR and paper invoices.
 - Deliver invoices via FTP, CD and Paper

Connectivity - Billing / CDG - Michael Tartaglione

Verizon's CABS billing conversion to CDG's carrier access system

- Customers currently utilizing Verizon's NDM option must complete the CDG access paperwork to continue with an electronic billing format (FTP), **otherwise the billing format will default to paper.**
- Any Customer wishing to utilize electronic billing, must also complete the CDG access paperwork to secure a password and gain access to the site:
 - Secure site / password protected
 - Easy setup, no VPN required
 - Email notification as BDT files are made available on site

Connectivity - Billing / CDG - Michael Tartaglione

- Electronic – via secure FTP site
 - Requires receipt of completed FTP Access form to establish account / gain access to site
 - Requires customer to obtain FTP client and appropriate software to read BDT files
 - Notification provided as BDT files are posted, as they are only available for 15 days
- CD ROM
 - Request written request via email
- Paper
 - Default – no action required

Connectivity - Payments - Michael Tartaglione

- Electronic
 - Payments can be made via Wire Transfer
 - Requires email request to secure specific bank routing number and remittance file requirements
- Check
 - Payments by check will be via lockbox
 - Specific address will be provided in subsequent industry letter (Oct 2008)
- Electronic / Check payments should be directed to FairPoint commencing February 2009
- Payments made to Verizon after February 2009 may result in the delay of payment posting

Customer Account Records Exchange - CARE - Pat Block

What is a transaction code and status indicator (TCSI)?

- CARE uses 2-byte transaction codes to convey the type of activity reported on:
 - Transaction Codes 01 to 19 are generated by inter-exchange carriers (IXCs)
 - Transaction Codes 20 to 61 are currently supported by local service providers (LSPs).
- Status indicators are used to define more clearly the transaction code activity.
- Because both TC and SI are essential to provide full information on the end user activity, they are usually thought of as one entity – TCSI.

Customer Account Records Exchange - CARE - Pat Block

When is CARE used?

- In general, a CARE transaction needs to be generated when any of the following situations occur:
 - A new customer signs up for service with a local service provider and selects a primary long-distance carrier.
 - Changes are made to an existing customer's account (e.g., an update to billing information, change to class of service, etc.)
 - A long-distance company submits an order to switch a customer to its long-distance service.
 - A long-distance company requests the billing name and address for a customer in order to bill usage (BNA Request).

Customer Account Records Exchange - CARE - Pat Block

- **Can CARE be exchanged with non-participants?**
 - **Yes, CARE can be exchanged with non-participants via our fax gateway and spreadsheets.**

Wholesale Customer Checklist - Deb Wall

APPLICATION	FAIRPOINT CONNECTION OPTIONS	FAIRPOINT CONTACT NAME PHONE/EMAIL	3RD PARTY CONTACT NAME PHONE/EMAIL
E911 (State of Maine only)	Available via HTTP, SFTP or dial up	fairpoint911@intrado.com	Intrado 911NET

E911 Data Flow Overview - State of Maine Deb Wall

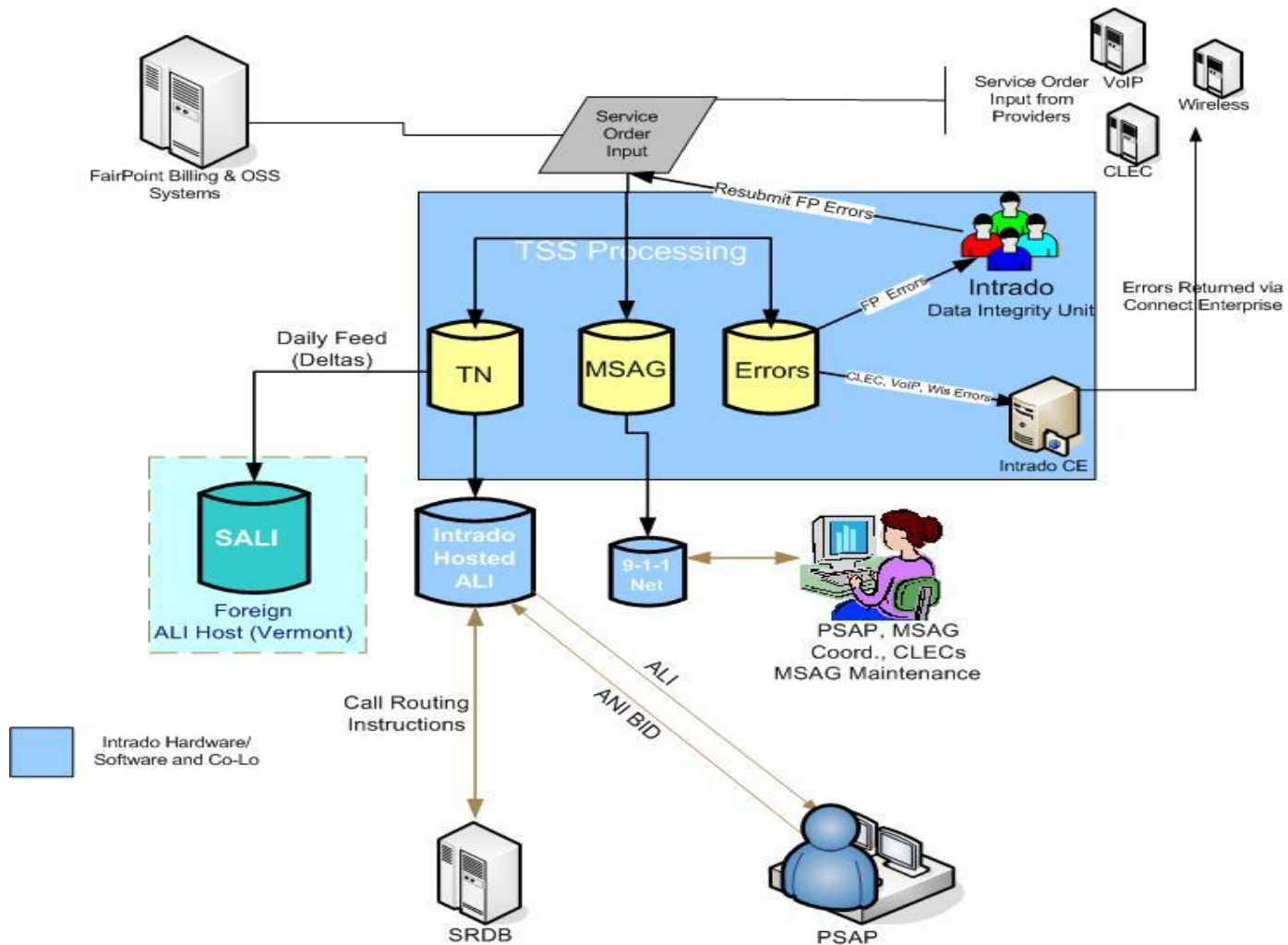

Wholesale Customer Checklist - Claudia D'Amato

APPLICATION	FAIRPOINT CONNECTION OPTIONS	FAIRPOINT CONTACT NAME PHONE/EMAIL	3RD PARTY CONTACT NAME PHONE/EMAIL
TCAP SERVICES (LIDB, CNAM, Toll- Free, LNP, AIN, ISVM, and CLASS)	NA Customer needs to provide point codes via the TCAP questionnaire	<u>TCAPServices@fairpoint.com</u> or Claudia D'Amato (207) 648-3149	Verisign

Wholesale Customer Checklist - John Berard

APPLICATION	FAIRPOINT CONNECTION OPTIONS	FAIRPOINT CONTACT NAME PHONE/EMAIL	3RD PARTY CONTACT NAME PHONE/EMAIL
LINE LOSS REPORTS	Available via Wholesale Customer Portal. Customer can pull the report from the site.	John Berard, jberard@fairpoint.com (207) 648-3085	N/A

Wholesale Customer Portal - John Berard

What will the portal do?

- Provides a single point of entry for access to FairPoint applications and reports
- Reports Delivery – Bulk Loop Qualification, Listing Verification, CSR 10k, Line Loss
- Applications – Profile Management, Wholesale Help Desk Trouble Ticketing Tool

What Customers need to do?

- Signup for Portal Access – Accessible Letter late October.
- Designate a Subscription Manager to manage access
- Login to the portal to pull down reports or use FairPoint applications



FairPoint Wholesale User Forum Lunch Break - 60 minutes

October 30, 2008



FairPoint Wholesale User Forum Question and Answer Review

Rich Murtha, AVP Wholesale Customer Operations
John Berard, Director Wholesale Customer Relations

October 30, 2008

Question and Answer Session

